



9th – 17th October, 2011



The Federation of Motor Sports Clubs of India

SUPPLEMENTARY REGULATIONS

X-TREME

H I M A L A Y A N M O T O R S P O R T

Motoworld, Navbahar,
Himachal Pradesh,
India

Phone: +91 (0) 177 2842917

Fax: +91 (0) 177 2844338

Email: info@raid-de-himalaya.com

Website: www.raid-de-himalaya.com

ANNOUNCEMENT

The MARUTI SUZUKI RAID DE HIMALAYA 2011, will be run in compliance with the National Competition Rules (NCR) & General Prescriptions of the FMSCI, these Supplementary Regulations and bulletins issued by FMSCI. Modifications, amendments and/or changes to these Supplementary Regulations will be announced only by numbered and dated bulletins (issued by Organisers or the Stewards).

Rights & Obligations Of The Organisers

The Organising Committee and the Stewards of the Meeting reserve the right to amend the prescriptions of the present regulations according to the circumstances and cases which arise. The organisers may also issue any Competitor Information Bulletins (CIBs) and/or written instructions to competitors at any time with the approval of FMSCI / Stewards. Written instructions when issued shall be signed by each competitor/entrant as proof of receipt and shall have the same legal force as these Supplementary Regulations. All CIBs will be communicated via dated and sequentially numbered bulletins. These bulletins shall have the force (and will constitute an integral part) of these regulations and will be posted at Meet HQ. As far as possible, the CIBs shall be brought to the notice of the individual competitor. However, it is the responsibility of the competitor and/or entrant to acquaint themselves with the CIBs and or written instructions posted at the official notice boards.

SUPPLEMENTARY REGULATIONS

MARUTI SUZUKI RAID DE HIMALAYA X-TREME 2011

INDEX		
Sr. No.	Details	Page
1.	Programme	4
2.	Description	8
3.	Organization	10
4.	General Conditions	12
5.	Eligible Vehicles	12
6.	Entries	14
7.	Insurance	18
8.	Advertising	19
9.	Obligations	20
10.	Scrutineering, Sealing and Marking	22
11.	Start of THE RAID	23
12.	Running of X-TREME 4X4	24
13.	Controls General Provisions	26
14.	Service	31
15.	Penalties	33
16.	Requests Protests & Appeals	35
17.	Classification	36
18.	Prizes and Trophies	36
19.	Appendix I - Duties of The Judges of Fact	38
20.	Appendix II - Competitors Relations Officer	39
20.	Appendix III – Duties of The Judges of Fact	40
21.	Appendix IV – Control Signs	41
22.	Appendix V – Advertising	42
23.	Appendix VI – Scrutiny List	43

PROGRAMME

Opening of Entries:

When: With the publication of these regulations
Where: Office of Himalayan Motorsport

Opening of Early Entries:

When: 1100 hrs: 1st April, 2011
Where: Office of Himalayan Motorsport

Closing Date of Early Entries:

When: 1700 hrs: 15th May, 2011
Where: Office of Himalayan Motorsport

Opening of Standard Entries:

When: 1100 hrs: 16th May, 2011
Where: Office of Himalayan Motorsport

Closing Date of Standard Entries:

When: 1700 hrs: 15th July, 2011
Where: Office of Himalayan Motorsport

Opening of Late Entries:

When: 1100 hrs: 16th July, 2011
Where: Office of Himalayan Motorsport

Closing Date of Late Entries:

When: 1700 hrs: 31st August, 2011
Where: Office of Himalayan Motorsport

Issuing of GPS Maps for Reconnaissance

When: 8th September 2011
Where: Office of Himalayan Motorsport

Publication of Entry List

When: 0930 hrs: 22nd September 2011
Where: Office of Himalayan Motorsport

Administrative Checks & Collection of Material and Documents

When: 0800 hrs: 9th October, 2011
Where: Office of Himalayan Motorsport

Scrutineering – Sealing and Marking

When: 0830 hrs: 9th October, 2011
Where: Motoworld, Shimla

(Schedule as per Art. 9.2 of these Supplementary Regulations)

Doctor's Briefing (For Doctors only)

When: 1900 hrs: 9th October, 2011
Place: Hotel Peterhof, Shimla

1st Stewards Meeting (For stewards only)

When: 1700 hrs: 9th October, 2011
Where: Hotel Peterhof, Shimla

Opening of Media Centre and Media Accreditation

When: 0900 hrs: 10th October, 2011
Where: Motoworld, Shimla

Pre Event Press Conference

When: 1200 hrs: 10th October, 2011
Where: HHH, Shimla

SUPPLEMENTARY REGULATIONS
MARUTI SUZUKI RAID DE HIMALAYA X-TREME 2011
Ceremonial Flag-off

When: 1600 hrs: 10th October, 2011
 Where: Driveway, Hotel Peterhof, Shimla

Publication of Start List & Order for Leg 1

When: 1700 hrs: 10th October, 2011
 Where: Office of Himalayan Motorsport

Compulsory Drivers Briefing

When: 1900 hrs: 10th October, 2011
 Where: Durbar Hall, Hotel Peterhof, Shimla

Entry to Parc Ferme for Leg 1 Starts

When: 0500 hrs: 11th October, 2011
 Where: Hotel Peterhof, Shimla

Entry to Parc Ferme Ends

When: 0500 hrs: 11th October, 2011
 Where: Hotel Peterhof, Shimla

Official Start of Leg 1

When: 0600 hrs: 11th October, 2011
 Where: Hotel Peterhof, Shimla

End of Leg 1

When: 1800 hrs: 11th October, 2011
 Where: ABVIMAS, MANALI

Publication of Start List & Order for Leg 2

When: 2200 hrs: 11th October, 2011
 Where: ABVIMAS, MANALI

Entry to Parc Ferme for Leg 2 Starts

When: 0200 hrs: 12th October, 2011
 Where: ABVIMAS, MANALI

Entry to Parc Ferme Ends

When: 0230 hrs: 12th October, 2011
 Where: ABVIMAS, MANALI

Official Start of Leg 2

When: 0300 hrs: 12th October, 2011
 Where: ABVIMAS, MANALI

End of Leg 2

When: 2100 hrs: 12th October, 2011
 Where: Tourist Reception Centre, Leh

Publication of Start List & Order for Leg 3

When: 0300 hrs: 13th October, 2011
 Where: Tourist Reception Centre, Leh

Entry to Parc Ferme for Leg 3 Starts

When: 0430 hrs: 13th October, 2011
 Where: Tourist Reception Centre, Leh

Entry to Parc Ferme Ends

When: 0530 hrs: 13th October, 2011
 Where: Tourist Reception Centre, Leh

Official Start of Leg 3

When: 0800 hrs: 13th October, 2011
 Where: Tourist Reception Centre, Leh

End of Leg 3

When: 1800 hrs: 13th October, 2011
 Where: Tourist Reception Centre, Leh

Publication of Start List & Order for Leg 4

When: 2200 hrs: 13th October, 2011
 Where: Tourist Reception Centre, Leh

Entry to Parc Ferme for Leg 4 Starts

When: 2200 hrs: 13th October, 2011
 Where: Tourist Reception Centre, Leh

Entry to Parc Ferme Ends

When: 2300 hrs: 13th October, 2011
 Where: Tourist Reception Centre, Leh

Official Start of Leg 4

When: 0700 hrs: 14th October, 2011
 Where: Tourist Reception Centre, Leh

End of Leg 4

When: 1800 hrs: 14th October, 2011
 Where: Camp at Rangdum

Publication of Start List & Order for Leg 5

When: 2200 hrs: 14th October, 2011
 Where: Camp at Rangdum

Entry to Parc Ferme for Leg 5 Starts

When: 1900 hrs: 14th October, 2011
 Where: Camp at Rangdum

Entry to Parc Ferme Ends

When: 2200 hrs: 14th October, 2011
 Where: Camp at Rangdum

Official Start of Leg 5

When: 0630 hrs: 15th October, 2011
 Where: Camp at Rangdum

End of Leg 5

When: 1800 hrs: 15th October, 2011
 Where: Camp at Rangdum

Publication of Start List & Order for Leg 6

When: 2200 hrs: 15th October, 2011
 Where: Camp at Rangdum

Entry to Parc Ferme for Leg 6 Starts

When: 1900 hrs: 15th October, 2011
 Where: Camp at Rangdum

Entry to Parc Ferme Ends

When: 2200 hrs: 15th October, 2011
 Where: Camp at Rangdum

Official Start of Leg 6

When: 0600 hrs: 16th October, 2011
 Where: Camp at Rangdum

End of Leg 6
Finish of Raid de Himalaya 2011

When: 1700 hrs: 16th October, 2011
 Where: Hotel Centaur, Srinagar

Final Scrutineering

When: 0900 hrs: 17th October, 2011
 Where: Hotel Centaur, Srinagar

Publication of the Provisional Final Classification

When: 1100 hrs: 17th October 2011
 Where: Hotel Centaur, Srinagar

SUPPLEMENTARY REGULATIONS

MARUTI SUZUKI RAID DE HIMALAYA X-TREME 2011

Prize Giving

When: 1800 hrs: 17th October 2011
Where: SKICC, Srinagar

Rally Dinner

When: 2000 hrs: 17th October 2011
Where: Hotel Centaur, Srinagar

DESCRIPTION

1.1 Status of the event: National with International Zone Participation
 Name: **MARUTI SUZUKI RAID DE HIMALAYA 2011**
 Place: Shimla, India
 Date: October 9 to October 17, 2011.

1.2 **Permit No**
 FMSCI Permit Number:

1.3 **Location of Official Notice Boards**

- From publication of these regulations to 9th October, 2011 at the office of Himalayan Motorsport at MotoWorld, Nav Bahar, Shimla
- From the 10th October, 2011 at the Raid Headquarters of Himalayan Motorsport at the end venue
- Leg 1, 2, 3, 4, 5 & 6 end venue and after the Finish of the Raid at Raid Headquarters / Final Parc Ferme at the end venue.

1.4 **Location of Raid Headquarters**

DATE 2010	TIME		PLACE
	OPEN	CLOSE	
9 Oct	1000	1800	Office of Himalayan Motorsport
10 Oct	1000	1800	Hotel Peterhof, Shimla
11 Oct	1800	2200	ABVIMAS, Manali
12 Oct	1800	2200	Tourist Reception Centre, Leh
13 Oct	1800	2200	Tourist Reception Centre, Leh
14 Oct	1800	2200	Camp at Rangdum
15 Oct	1800	2200	Camp at Rangdum
16 Oct	1800	2200	Hotel Centaur, Srinagar
17 Oct	800	1500	Hotel Centaur, Srinagar

Location of Start and Finish

Start of Leg 1	11th October, 2011
Place	Hotel Peterhof, Shimla
End of Leg 1	11th October, 2011
Place	ABVIMAS, Manali
Start of Leg 2	12th October, 2011
Place	ABVIMAS, Manali
End of Leg 2	12th October, 2011
Place	Tourist Reception Centre, Leh
Start of Leg 3	13th October, 2011
Place	Tourist Reception Centre, Leh

SUPPLEMENTARY REGULATIONS
MARUTI SUZUKI RAID DE HIMALAYA X-TREME 2011

End of Leg 3	13th October, 2011
Place	Tourist Reception Centre,Leh
Start of Leg 4	14th October, 2011
Place	Tourist Reception Centre , Leh
End of Leg 4	14th October, 2011
Place	Camp at Rangdum
Start of Leg 5	15th October, 2011
Place	Camp at Rangdum
End of Leg 5	15th October, 2011
Place	Camp at Rangdum
Start of Leg 6	16th October, 2011
Place	Camp at Rangdum
End of Leg 6	16th October, 2011
Place	Hotel Centaur,Srinagar

1.5 Location of Parc Ferme at Start for each leg

LEG	DATE	LEG START Parc Ferme
1	11 Oct	Hotel Peterhof, Shimla
2	12 Oct	ABVIMAS, Manali
3	13 Oct	Tourist Reception Centre, Leh
4	14 Oct	Tourist Reception Centre, Leh
5	15 Oct	Camp at Rangdum
6	16 Oct	Camp at Rangdum

1.6 Location of Media Room

Date	Time	Location of Media Room
11th Oct, 2011	From 0600hrs	Hotel Peterhof, Shimla
12h Oct, 2011	From 0900 hrs	Tourist Reception Centre, Leh
13h Oct. 2011	From 0900 hrs	Tourist Reception Centre, Leh
14th Oct. 2011	From 0900 hrs	Camp at Rangdum
15th Oct.2011	From 0900 hrs	Camp at Rangdum
16th Oct 2011	From 0900 hrs	Hotel Centaur, Srinagar
17th Oct 2011	From 0900 hrs	Hotel Centaur, Srinagar

ORGANISATION

2.1 **Organiser's Name:** **Himalayan Motorsport Association**

2.2 **Address & Contact Details:** **Himalayan Motorsport**
Motoworld, Navbahar, Shimla,
Himachal Pradesh - India
Phone: +91 (0) 177 2842916
Fax: +91 (0) 177 2844338
Email: info@raid-de-himalaya.com

2.3 **Name of the National Sporting Authority**
The Federation of Motor Sports Clubs of India,
"Krishna Towers – I", VI Floor, Apt. # 25, New No. 50,
Sardar Patel Road, Chennai – 600 113
Tamil Nadu - India

Chief Patron

Prof. Prem Kumar Dhumal

Hon. Chief Minister Himachal Pradesh

2.4 **Organisation Committee**

Mr.V. C. Pharka IAS	Mr. Kalyan Singh CEO Bhaderwah	Mr. Atal Dulloo IAS
Mr. Mohd. Ashraf IAS	Mr. Farooq Shah	Mr. Navdeep Thareja
Mr. Atul Handa	Mr. Avishkar Ranjan	Mr. R.S Dhaliwal
Mr. Kapil Nagu	Ms. Mamta Handa	Ms. Madhu Parmar
Ms. Rajni Nagu	Mr. Manjeev Bhalla	Mr. Vijay Parmar

2.5 **Stewards of the Meeting**

Chief Steward	Mr. Ravi Singhania
Stewards	Mr Hari Singh Dr. Shekhar Verma

2.6 **FMSCI Scrutineer**

Chief Scrutineer	Mr. Bhaskar Patwardhan
Asst. Scrutineer	Mr. Sanjay Sankhla

SUPPLEMENTARY REGULATIONS

MARUTI SUZUKI RAID DE HIMALAYA X-TREME 2011

2.7 Senior Officials

Clerk-of-the-Course	Mr. Manjeev Bhalla
Secretary of the Meet	Mr. Kapil Nagu
Competitor Relation Officer	Th. Jaideep Singh
Chief Medical Officer	Dr .S Caprihan
Chief Safety Officer	Mr. Samar Sodhi
Media Relations Officer	Mr. Kishie Singh
Communication Chief	Mr. Suhrid Sharma
Chief Time Keeper	Mr. Hywel Thomas
Results	Rally Results International

Area Coordinators

Area Coordinator (Shimla)	Mr. Sanjay Kumar
Area Coordinator (Manali)	Mr. R.S.Dhaliwal
Area Coordinator(Leh)	Mr. Navdeep Thareja
Area Coordinator(Rangdum)	Mr. Parveen Grover
Area Coordinator(Srinagar)	Mr. R. S. Dhaliwal

2.8 JUDGES OF FACT :

All persons (other than stewards) named in Art. 2.7. Duties of the Judges of Fact are described in Appendix I.

2.9 Identification of Officials

The Post Chiefs and other marshals will be identified as follows:

Scrutineers:-	Light Blue Vest with Black “SCRUTINEER”
Deputy Clerks of The Course:-	Lime Green Dayglo Safety Vests

GENERAL CONDITIONS

- | | | |
|-----|--|----------|
| 3.1 | Total distance of the course | 2200 Kms |
| 3.2 | Number of Competitive Section | 11 |
| 3.3 | Total distance of the Competitive Section | 667 Kms |
| 3.4 | Total number of Transport and Competitive Section combined | 28 |
| 3.5 | Number of legs | 6 |
| 3.6 | Competitive Section Description of Type of Road Surface: | |

Leg	% TARMAC	% DIRT
Leg 1	10	90
Leg 2	80	20
Leg 3	100	0
Leg 4	60	40
Leg 5	0	100
Leg 6	0	100

ELIGIBILITY OF VEHICLES

4.1 Groups and Classes

The Classes formed are on the basis of cylinder capacity as follows:

Group T1 Modified Cross Country Vehicles 2WD and 4WD

Class 1	From 700cc	Up to 1000cc
Class 2	Over 1000cc	Up to 1400cc
Class 3	Over 1400cc	Up to 2000cc

Group T2 Series Cross Country Vehicles 2WD and 4WD

Class 4	From 700cc	Up to 1000cc
Class 5	Over 1000cc	Up to 1400cc
Class 6	Over 1400cc	Up to 2000cc

Group T4 Series Cross Country Vehicles 2WD and 4WD Trucks

Class 7	From 1000cc	Up to 6000cc
---------	-------------	--------------

- 4.2 Cars entered in a Group containing fewer than 5 cars will only compete for the Overall Classification (i.e. if there are less than 5 cars in Group T1 or Group T2 they will compete for the overall classification). If the number of the verified cars in the same cubic capacity class is below four, this class will be amalgamated with the class or classes above to attain the minimum of four cars.

SUPPLEMENTARY REGULATIONS

MARUTI SUZUKI RAID DE HIMALAYA X-TREME 2011

4.3 All cars entering T1, T2 and T4 groups will be governed by the FIA regulations for T1, T2 and T4.

4.4 EXCEPTION Applied for through waiver:

However the minimum weight required for T1 cars will not be the table specified, but the minimum homologated weight of the vehicle +40 Kilo grams for the roll cage. T2 cars have to maintain the weight as specified in the homologation form.

4.5 Vehicle Requirements

4.5.1 Tyres, including number and type, are optional provided the tread compound contains no form of metal. Use of any kind of metal, ceramic or composite spike or stud of whatever size, is prohibited. However, use of tyre chains is permitted provided they are not inset into the tyre in any way or used on bituminised road surfaces.

4.5.2 A VEHICLE WILL NOT BE ALLOWED TO START UNLESS IT IS EQUIPPED WITH SAFETY REQUIREMENTS AS SPECIFIED IN THE NCR OF THE FMSCI / APPENDIX J to ART. 253 OF THE ISC OF THE FIA.

These include:

1. **Roll bars / cage complying with FIA / FMSCI regulations.**
2. Safety harness (minimum 4 POINT HARNESS) for both driver & navigator
3. Two towing eyes painted red, one at the front end and one at the rear.
4. A tow chain / Strap made of steel wire / Nylon Strap
5. A fire extinguishing system.
6. First Aid Kit.
7. Two red reflective triangles. **(In the case of stopping in a competitive section, they will be placed by the crew more than 30 metres behind the car.)**
8. Mud flaps at the rear of the driving and rear wheels. Such mud flaps to be of very stout material at least 5 mm thick and 20 cm wide and fitted in such a manner as to completely mask the tyre when viewed from behind the car, the lower edge not to be more than 8 cm from the ground when the car is stationary. Hinged mud flaps are not allowed. Where exhaust systems interfere with mud flaps, such holes as are necessary may be drilled through the mud flaps to allow passage of the exhaust pipe(s).
9. It is permitted to install an auxiliary fuel tank in the car provided this is a tank manufactured by an OE supplier for use on a series production automobile. This may be mounted on a roof rack as well. If installed within the car this tank must be separated from the drivers cabin with a fire proof bulkhead and vent gases to the outside.
10. Additional fasteners for front or rear bonnet and boot lid, preferably bayonet type.
11. A General circuit breaker.
12. Noise testing as per rules under SCRUTINEERING will be mandatory and enforced. Removal of the catalytic converter core will result in exclusion.

For all the items that would be checked in the Pre Event Safety Scrutiny it is better to acquire a Scrutiny Check List from the rally office. Technical conformity to the Group entered will be as per the 4 wheel Technical Regulations of the FIA.

4.5.3 All competing cars must:

1. Comply with the legal requirements of cars used on public roads in India. Any absence or malfunctioning of electrical or mechanical parts which are required by the traffic regulations will result in a penalty of Rs. 300/- for each such offence, e.g., one of the rear lights not working.
2. Ensure that wireless and/or radio communication equipment/transmitters conform to legal requirements and are sanctioned by the Competent Authority in India. Photocopy of license aboard each car fitted with VHF radio. In case of non-compliance the radio will be removed and deposited with the organisers for the length of the rally and a fine of Rs. 10,000/- imposed.
3. Carry emergency rations and drinking water sufficient for a minimum of 24 hrs.
4. Sleeping bags for all crew to be carried on board at all times.

4.5.4 Recommended equipment:

1. Protective shields can be fitted to the underside of the car. Such shields may take the form of complete underneath protective devices or may be used to protect individual components
2. Strengthening of the aprons and lower control arms, mounting points to prevent spreading is permitted and free for all groups and classes.
3. Strut braces are permitted for T1, T2 and T4 groups.

4.5.5 Miscellaneous:

1. Spare components and tools, if carried in the passenger compartment, must be securely fastened or the entrant of the vehicle concerned will be reported to the Stewards of the Meeting who may impose a fine.
2. The spare wheel(s) need not occupy the position(s) provided by the manufacturer.
3. Minimum drilling of the coachwork is permitted to enable the fitting of any additional devices detailed in these Supplementary Regulations.
4. Rear seats need not be carried.

The Organizer will provide advice on any requirement of Article 4 on request. The web site www.raid-de-himalaya.com has links to the relevant technical drawings and regulations of the FiA for 2011. For the items that will be checked at pre event safety scrutiny please see Appendix VI. Permitted Modifications are as per 4 wheeler techregs of the FSMCI/ FiA.

ENTRIES

5.1 Opening and Closing Dates

As per programme

5.2 Entry Procedure

Those wishing to take part in the **MARUTI SUZUKI RAID De HIMALAYA 2011** must send the Entry Form, which is available on our website www.raid-de-himalaya.com, or from the office of Himalayan Motorsport, duly completed to the Permanent Secretariat at the address given in Art 2.2. as per programme. If the entry is sent by facsimile or email the original must reach the Organisers at the latest by the final date for close of entries for that type of entry.

The last dates for submission of all documents are as per the following type of entry :

EARLY ENTRIES

Early entries are those made from the 1st April to 15th May, 2011. For early

SUPPLEMENTARY REGULATIONS

MARUTI SUZUKI RAID DE HIMALAYA X-TREME 2011

entrants all documentation as given at the end of the Entry Form has to be completed in all respects by the 15th June 2011 latest. If not the Entry will be treated as a Standard Entry and the balance money will have to be deposited immediately.

STANDARD ENTRIES

Standard entries are those made between 16th May and the 15th July, 2011. For standard entrants all documentation as given at the end of the Entry Form has to be completed in all respects by the 15th August, 2011 latest. If not the Entry will be treated as a Late Entry and the balance money will have to be deposited immediately.

LATE ENTRIES

Late entries are those made between 16th July and the 31st August, 2011. For late entrants all documentation as given at the end of the Entry Form has to be completed in all respects by the 21st September, 2011 latest. If not the Entry will be treated as a Very Late Entry and the balance money will have to be deposited immediately.

VERY LATE ENTRIES

Very Late entries are those made between 1st September and the 21st September, 2011. For late entrants all documentation as given at the end of the Entry Form has to be completed in all respects by the 21st September 2011 latest. If not, the Entry will be rejected outright.

5.3 Number of Entrants accepted and classes

The maximum number of entries accepted shall be no more than 40 cars. The organisers reserve the right to increase the number. If more than 40 entries are received the organizers reserve the right to decide how many and which entries will be accepted.

5.4 Complete details as required on the entry form must be submitted in order to qualify for Standard Entry Fee. In case of any details being incomplete the entry will be invalid.

5.5 Only one member of the crew / vehicle may be changed:

5.5.1 Before the Start of scrutineering, with the agreement of the Organising Committee and with a fine of Rs. 5,000/-.

5.5.2 Once the scrutineering has started, with the agreement of the Stewards of the Meet and with a fine of Rs.5,000/-.

5.5.3 The changing of both members of the crew is not permitted.

Any such change shall not be permitted unless applicable fees as detailed above has been paid to the organisers.

5.6 Entry forms which are not complete, except as permitted by these regulations or which are not accompanied with the appropriate fee may be rejected.

5.7 No amendments may be made to the entry form which has been submitted, except in the cases provided for in the present regulations.

5.8 By the very fact of signing the entry form, the entrant as well as the driver, navigator and crew submit and bind themselves to resort only to the prescriptions of these regulations.

5.9 An entry form which contains false and/or incorrect statements shall be deemed null and void and the entrant may be deemed guilty of breach of these regulations and the entry fee may be forfeited and the entrant excluded from the Meet.

5.10 Any change of the entrant is prohibited after the closing of entries. Entry fee cannot be transferred to another entrant at any time before the event.

Entry Fees

- 5.11 The entry fees specified in 5.2 include an opportunity for the crew to participate in the Maruti Suzuki Raid de Himalaya 2011, one set of Road Books, Route Maps and an invitation for the driver and co-driver to the PRIZE DISTRIBUTION FUNCTION and Rally Ball.
- 5.12 The Entry Fees will provide lodging on twin sharing basis on the night of 10th October, 2011, for those who have cleared scrutiny. The Entry Fee also includes basic accommodation at the Night Halts on the days of the actual running of the Raid as long as the **competitor has not retired from the competition or been excluded for any reason whatsoever**. Wherever the entrant has started a Leg and reached the official night halt he/she will be provided hospitality for that night even though he may have retired from the event anywhere along that Leg. Hospitality will cease from the next day onwards. No retired competitor will be permitted to start the next leg even if he/she desires to complete the route in a non competitive way and the organisers are not responsible for the safety, hospitality or medical contingencies for such retired competitors.

Food, as and when provided, is at the discretion of the organisers.

Medical rescue and evacuation will be by land and the organisers do not guarantee quality or a time frame for this. All competitors will sign the required indemnity before participating, However, all competitors, finishers and retired, are invited for the Prize Distribution and for that night the accommodation will be provided by HMA.

Entry Fee does not cover vehicle recovery, medical charges, fuel, etc. These may be provided at the discretion of the organisers on a case to case basis without their having to assign any reason or explanation of their decision whatsoever.

- 5.13 WITH THE OPTIONAL ADVERTISING PROPOSED BY THE ORGANISERS

Early Entry

(Between 1st April and 15th May, 2011) 2WD and 4WD)

T1	Cars	Rs. 40,000
T2	Cars	Rs. 40,000
T4	Trucks	Rs. 40,000

Standard Entry

(Between 16th May and 15th July, 2011) 2WD and 4WD)

T1	Cars	Rs. 50,000
T2	Cars	Rs. 50,000
T4	Trucks	Rs. 50,000

SUPPLEMENTARY REGULATIONS

MARUTI SUZUKI RAID DE HIMALAYA X-TREME 2011

Late Entry

(Between 16th May and 15th July, 2011) 2WD and 4WD)

T1	Cars	Rs. 60,000
T2	Cars	Rs. 60,000
T4	Trucks	Rs. 60,000

Very Late Entry

(Between 1st September and 21st September, 2011) 2WD and 4WD)

T1	Cars	Rs. 78,000
T2	Cars	Rs. 78,000
T4	Trucks	Rs. 78,000

SPONSORED OR WITHOUT OPTIONAL ADVERTISING /

Early Entry

(Between 1th April and 15th May, 2011) 2WD and 4WD)

T1	Cars	Rs. 80,000
T2	Cars	Rs. 80,000
T4	Trucks	Rs.80,000

Standard Entry

(Between 16th May and 15th July, 2011) 2WD and 4WD)

T1	Cars	Rs. 1,00,000
T2	Cars	Rs. 1,00,000
T4	Trucks	Rs.1,00,000

Late Entry

(Between 16th July and 31st July, 2011) 2WD and 4WD)

T1	Cars	Rs. 1,20,000
T2	Cars	Rs. 1,20,000
T4	Trucks	Rs.1,20,000

Very Late Entry

(Between 1st September and 21st September, 2011) 2WD and 4WD)

T1	Cars	Rs. 1,56,000
T2	Cars	Rs. 1,56,000
T4	Trucks	Rs. 1,56,000

5.14 REFUNDS

No entry fee refunds after 31st August 2011 for any reason whatsoever. Minimum deduction of entry fee before that date is 50% and refunds are for a proven, valid reason **OR IN THE EVENTS DESCRIBED UNDER Art 5.17.**

5.15 Sponsored Entry is classified as below:

- a. If an entry is made by a vehicle/ancillary manufacturer, his franchise holder, accredited dealers, agents or sub-agents.
- b. If the entry is or becomes a member of a manufacturer's team.
- c. If the entry is in respect of a vehicle, which, in the opinion of the organisers, has, been provided by a vehicle/ancillary manufacturer or any person or organisation acting as his agent.
- d. The vehicle displays ANY advertising mentioned other than compulsory advertising.
- e. If the vehicle is painted in colour scheme/ design of vehicles of major sponsors, whether carrying the sponsors advertising or not, which in the opinion of the organizers is a sponsored vehicle.
- f. The decision of the organizers in this matter will be final and binding on the competitor.
- g. If any of the advertising material is infringing with the standard pattern of mandatory **advertising as given in Appendix V**, the entry will be considered as sponsored entry and the fee shall be twice that for the relevant date of entry.

5.16 The application form will only be accepted if accompanied by the total entry fees.

5.17 Entry fees will be refunded in full ONLY to those candidates whose entry has not been accepted. In case the Raid does not Flag Off, 20% WILL BE RETAINED AND THE REST REFUNDED.

5.18 Team Entry – in addition to prevailing entry fees.

Manufacturers Team Entry	Per Team (3-5 car)	Rs. 5,00,000
Commercial Team Entry	Per Car	Rs. 15,000
Club Team Entry	Per Car	Rs. 3,000

5.19 Entries will only be accepted if accompanied by full entry fee. Entries may be paid in cash or by Demand Draft favouring the organizers.

5.20 Sponsored entries are not obliged to carry Organizer's "Optional Advertising" but are obliged to carry "Compulsory Advertising" as per details which are listed in Appendix V.

5.21 Payment

The entry can be paid either by *Demand Draft* in favour of "**Himalayan Motorsport**" OR by Cash or by Bank Transfer, the details of which are on our website.

INSURANCE

6.1 Description of Insurance Cover:

Cover provided by FMSCI with permit

ORGANIZERS HOLDING A VALID 2011FMSCI PERMIT FOR AN EVENT ARE COVERED FOR.

SUPPLEMENTARY REGULATIONS

MARUTI SUZUKI RAID DE HIMALAYA X-TREME 2011

- THIRD PARTY PUBLIC LIABILITY FOR RS. 50 LAKHS VALID DURING THE RUNNING OF THE EVENT ONLY.
- A MAXIMUM OF 100 OFFICIALS OFFICICATING &
- 150 COMPETITORS WITH VALID FMSCI COMPETITION LICENCE PARTICIPATING IN VARIOUS EVENTS ACROSS THE COUNTRY ON A GIVEN DAY ARE COVERED FOR PERSONAL ACCIDENT INSURANCE FOR RS. 2 LAKH WITH RS.40,000/- MEDICAL EXPENSES EXTENSION PER PERSON .THESE INSURANCES ARE ISSUED BY UNITED INDIA INSURANCE COMPANY LTD. VALID DURING THE RUNNING OF THE EVENT ONLY.ORGANIZERS /COMPETITORS ARE ADVISED TO TAKE AWAY ANY ADDITIONAL INSURANCES. THEY MAY DEEM FIT.

Public Liability: Insurance for Rs. 50,00,000/- which adequately covers any Liability incurred during the running of the event for injury to Third Persons of Damage to Public Property has been taken

All competitors are to take a further personal accident insurance for Rs.2,00,000/- each including hospitalization benefits. This insurance should be normal insurance, but specifically “High Risk” insurance Mediclaim policies above Rs.2,00,000/- will be accepted. The insurance cover should be valid from October 10th to October 17th 2011, both days included.

- 6.2 All competitors are to take further personal accident insurance for Rs.2,00,000/- each including hospitalization benefits. This insurance should not be normal insurance, but specifically “High Risk” insurance. Mediclaim policies above Rs 2,00,000/- will be accepted. The insurance cover should be valid from October 10th to October 17th, 2011, both days included.
- 6.3 The insurance of each vehicle against Third Party risk is the minimum requirement as per the Laws in India. Proof that the vehicle is insured will be required prior to the closing of entries. **ENTRANTS/DRIVERS ATTENTION IS PARTICULARLY DRAWN TO THE FACT THAT NORMAL MOTOR POLICIES ISSUED IN INDIA DO NOT PROVIDE COVER FOR RALLYING.** As such all Competing vehicles will have to be insured by taking a special Rally insurance for the event. Proof of such insurance cover will have to be produced before start of Scrutineering.

ADVERTISING

- 7.1 Advertising on competing cars is allowed provided that:
- a) ALL instructions issued by the organisers are observed.
 - b) No advertising material shall be placed on any of the side windows. The top 3 inches of the front and rear windshields are reserved as follows:
 - c) Top 3 inches of front windshield – Maruti Motorsports sticker.
 - d) Top 3 inches of rear windshield — Himalayan Motorsport sticker.
 - e) Advertising must not be of a political, obscene or insulting nature and must be in good taste and not conflict with the vehicles official numbers in such a way as to prevent recognition by Officials or Marshals.
 - f) All religious advertising, including messages and symbols of faith, are not permitted.
 - g) The front doors shall be left free of advertising other than that provided by the organisers.
 - h) Space required as indicated in Article 7.2 is left free of advertising other than that provided by the organisers.

- i) Even after the event the Competitors may collectively and individually be held responsible for any advertisement infringing Article 7.1.
- j) All stickers/ advertising of other rallies have to be completely removed before the new stickers will be applied.
- k) No numerical numbers can be displayed under any circumstances. Armed Forces vehicles wishing to display regimental / formation numbers can only write them as text. E.g 62 Cavalry can be written as Sixty Two Cavalry. The numerals conflict with the Competition numbers and are therefore prohibited.

7.2 Advertising is as indicated in Appendix V and all competitors will be bound by this article.

OBLIGATIONS

Rights & Obligations Of The Organisers

- 8.1 The Organising Committee and the Stewards of the Meet reserve the right to amend the prescriptions of the present regulations according to the circumstances and cases which arise. The organisers may also issue any Competitor Information Bulletins (CIBs) and/or written instructions to competitors at any time. Written instructions when issued shall be signed by each competitor/entrant as proof of receipt and shall have the same legal force as these Supplementary Regulations. All CIBs will be communicated via dated and sequentially numbered bulletins. These bulletins shall have the force (and will constitute an integral part) of these regulations and will be posted at Meet HQ. As far as possible, the CIBs shall be brought to the notice of the individual competitor. However, it is the responsibility of the competitor and/or entrant to acquaint themselves with the CIBs and or written instructions posted at the official notice boards.
- 8.2 The Stewards of the Meeting are empowered to take a decision on any case not covered by the present regulations.
- 8.3 The organisers may at their discretion, abandon, cancel or postpone the Meet, in case of unforeseen circumstances.
- 8.4 The organisers and/or the Clerk of the Course reserve the right to delete and/or change any part of the route should they deem it necessary or expedient at any time or due to FORCE MAJEURE or for any other reason.
- 8.5 THE ORGANISERS RESERVE THE RIGHT TO REFUSE ENTRY OF ANY ENTRANT OR PARTICIPANT WITHOUT HAVING TO GIVE REASONS FOR THEIR REFUSAL.
- 8.6 The organisers and/or the Clerk of the Course may appoint Judges of fact.
- 8.7 The interpretations of these regulations and decisions regarding any unforeseen circumstances shall rest with the Stewards of the Meeting.

General Obligations of Competitors & Organisers

- 8.8 All competitors must be the holder of a currently valid FMSCI Rally License.
- 8.9 If the entrant is not the competitor, the 1st driver nominated on the entry form shall be deemed to be the entrant. Whenever an entrant or competitor is referred to in these regulations this shall also mean his / her agents, if appropriate.
- 8.10 The Stewards of the Meeting may exclude a Competitor who was found under the influence of alcohol / intoxicating drugs **or who is deemed unfit for reasons of health or lack of ability required for participation in such an event** and

SUPPLEMENTARY REGULATIONS

MARUTI SUZUKI RAID DE HIMALAYA X-TREME 2011

reported by the Clerk of the Course or his nominated officials.

- 8.11 All Competitors must sign the indemnity / declaration which are printed on the Entry form.
- 8.12 Any indemnity and / or declaration as prescribed by the paragraph above if signed by person under the age of 18 years, shall be countersigned by that person's parent or guardian whose full name, address and capacity in which he is countersigning shall be given.
Failure to do so will result in the competitor not being allowed to start.
- 8.13 Under the Laws of India any accident out of which a claim may arise should be reported to the nearest police station.
- 8.14 Should a competing vehicle come across another vehicle which has met with an accident, it is their duty to ensure that the crew of that vehicle does not need any medical attention. If medical assistance is required they may take the injured person on board in violation of Art. 8.15: **Note: Failure to provide such assistance / Failing to report any breakdown / accident to the next official on the route may lead to exclusion at the discretion of the Stewards. Those competitors that may withdraw from the event are required to hand in their Time Card to any official. Failing to inform the organisation of their departure will entail a request from HMA to the FMSCI for suspension of Competition Licenses.**
- 8.15 A competing vehicle shall only carry the two people named on the Entry Form on board at all times. **Both driver and co-driver must have seat belts on throughout the entire event both on transport and competitive stages. First offence fine is Rs. 5,000/-. Second offence is exclusion.**
- 8.16 Under NO circumstances will any Competitor, Crew Member, Marshal or Official admit any liability or sign any form or paper which may admit or indicate liability of the Sponsors and/or the organisers in any accident or incident which may arise.
- 8.17 The Scrutineering Card, Identity Card and Identity Tags, the competition numbers, plates/stickers and Organizer's advertising as applicable can be collected at the time of scrutiny.
- 8.18 An Identity card will be provided by the organizers and must be displayed inside each competing car.
- 8.19 Raid stickers & Competition Numbers will be provided by the organizers.
- 8.20 As the Road books are being made available in advance for reconnaissance the option to recce the route lies with the Competitor.
- 8.21 Competitors attention is drawn to the fact that the route passes through remote villages and they are thus advised to exercise extreme caution while passing through them. Any untoward incident during the recce is likely to adversely impact the event and will be treated as a police matter.
- 8.22 Use of Aviation fuel (Avgas) is permitted as per Regulations of the FIA. Participants will, however, have to arrange for their Avgas requirements on their own.
- 8.23 Competitors are forbidden under pain of exclusion to behave in any unsporting manner.

SCRUTINEERING, SEALING & MARKING

Scrutiny -

Pre-event scrutiny will be essentially safety scrutiny. This will ensure conformity to the Scrutiny Checklist (Appendix IV). The issue of a SCRUTINY OK STICKER is not a guarantee that the vehicle has passed technical conformity as per these Supplementary Regulations.

During the event, any Marshall/ Raid Official/ Judges of Fact can carry out on the spot scrutiny of the vehicle to ensure safety/ technical conformity of the vehicle/ competitors. The observations on the vehicle's safety/technical conformity by a Judge of Fact would be final.

Post-event Scrutiny will decide the vehicles conformity to these Supplementary Regulations with regard to any observation that might have been made during the running of the event.

9.1 Venue: MotoWorld, Navbahar, Shimla

From : 0830 hrs Sunday 9th October and Monday 10th October, 2011

9.2 Time/Schedule

All the competitors shall be informed individually through letters regarding their date and time of Scrutiny.

The timings for the Pre Event Scrutiny for X-treme Cars as follows-

Date	Start Time	End Time	Competition Nos
9th October 2011	0830 Hrs	1800 Hrs	1 st LOT
10th October 2011	0800 Hrs	1400 Hrs	2 nd LOT

9.3 Drivers taking part in the Raid must arrive at scrutineering with full crew, driving gear, snow chains and car as per given schedule.

9.4 At scrutineering crew members will be asked to produce their identity cards.

9.5 The scrutineering card must be carried in the vehicle throughout the event. This scrutineering card must be produced to any official on demand and surrendered at the finish. Loss of the scrutineering card will result in exclusion.

9.6 Any car reporting to the scrutineering area outside the prescribed time limits will not be allowed to start, except in cases of 'force majeure' duly accepted as such by the Stewards of the Meet who may impose a fine.

9.7 Scrutineering carried out before the start will be of a general nature to ensure vehicles conform to these Supplementary Regulations, the safety requirements, apparent conformity of the car with the Group in which it is entered, conformity of the car with the National Highway code, etc.

9.8 **Any vehicle which appears on external examination to be ineligible for the XTREME 4X4, only on grounds represented in the Scrutiny Check List, may be rejected and called back for re scrutineering on payment of the re-scrutineering fee of Rs 300/- for each recall. Issue of the 'Scrutiny OK' sticker cannot be deemed as acceptance of technical conformity for which clearing the technical Post Event Scrutiny is imperative.**

9.9 In order to prevent the engine or body shell from being changed during the event these items will be identified by the Organizers at pre start scrutineering, using wire and special numbered seals and/or paint.

SUPPLEMENTARY REGULATIONS

MARUTI SUZUKI RAID DE HIMALAYA X-TREME 2011

- 9.10 One paint mark will be placed on the body shell or chassis frame within the engine compartment and another on the engine block. Other means of identification may also be used. Missing marks will result in immediate exclusion. Any fraud discovered, in particular the fact of presenting as intact identification marks that have been retouched, will result in exclusion of the competitor from the event as well as that of any entrant or competitor who has helped / been involved in carrying out of the infringement.
Entrants/Drivers will be required to sign on the Scrutineering Card that identification has been carried out to their complete satisfaction.
Entrants uncertain of precise requirements should consult the Chief Scrutineer through Raid Headquarters.
- 9.11 All vehicles must be equipped with roll bars/cage complying with FMSCI specifications, and with all other safety devices as specified by FMSCI in the NCR. All main hoops of the roll cage (that is, main and lateral) should have a 6 mm hole for the Scrutineer to check wall thickness of the pipe.
- 9.12 Additional scrutineering (of crew members as well as of vehicles) may be carried out at any time during the event.
- 9.13 The competitor is responsible for the technical conformity of his car throughout the entire duration of the event.
- 9.14 Fine of Rs 300/- for each non working item as per the Scrutiny Checklist is to be deposited at the Post event scrutiny. Money shall be deposited in cash with the Scrutineer before the competitor can be declared a finisher / winner.
- 9.15 Scrutineering fines of Rs 300/- will be levied per non working item as per the scrutiny list at scrutiny carried out at any or every Leg end.
- 9.16 Environmental Scrutiny.
- a) **NOISE TESTING**
Sound level of all the participating vehicles shall be under the permissible limit at all times during the running of the Raid. The limits are 98/103 db, as prescribed. This will be measured from 2m behind the exhaust opening at 3000 rpm for petrol engines and 2000 rpm for diesels. Failing the Noise Test a start will not be allowed. Maximum at full rpm will be 103 db.
- b) **OIL SPILLAGE**
All cars must carry a Tarpaulin of size 4m x 3m which shall be spread on the ground for parking the car on top of it for any kind of repair works to be carried out on the cars including changing of tyre. Participants will be penalised upto pain of exclusion in case of non compliance. Oil that may spill must be mopped up by a rag will have to be disposed off suitably.

START OF THE RAID

- 10.1 **Publication of the starting lists.**
The start lists will be published on the Official Notice Board at Raid Headquarters as per programme
- 10.2 **Start Area/Start Parc Ferme**
- 10.2.1 All competitors must report to the starting area at the Hotel Peterhoff, Shimla (Parc Ferme) at least 60 minutes before the start of the event.
- 10.2.2 The vehicles may be presented by a representative of the entrant.
- 10.2.3 The starting area shall be regarded as a 'Parc Ferme'.
- 10.2.4 Competitors are required to line up for the start of the day at least 10 minutes before their Flag-off time. A competitor reporting late for Flag-off at any Day start

will be penalised @ 1 minute per 1 minute late upto 10 minutes lateness. **All late starters will start after the rest of the field. After 0:10:01 secs lateness the competitor will be excluded.**

RUNNING OF THE X-TREME 4X4

11.1 Paper Time Card and e-Time Card

There will be a dual timing system; the timing will be manually recorded in the paper time card and will be electronically stored in the e-Time Card.

In this case, a paper Time Card & e-Time Card will be issued to each competing crew at the start of the Xtreme Raid. Responsibility for the paper time card & e-Time Card rests solely with the crew until it is handed back to an official or marshal of the RAID.

Security deposit for the e-Time Card:

A security deposit of Rs. 2000/- would be taken from all competitors for the e-Time Card used during the running of the Xtreme 4X4. This card is the property of the organisers and to get the refund, the card has to be deposited with the authorities at the finish venue, or at any leg end, where the competitor drops out. Not producing the e-Time Card at a time control / loss of the e-Time Card entails exclusion for kit are of deposit.

On the time cards the following details will be given

a) Competition number

At every control, the crew must ensure that the time card is signed by the marshal and the marshal's card is signed by the competitor and (except in the case of passage controls) that the correct time is entered and that the e-Time Card is swiped with the Liege Timer which constitutes the marshal's official clock.

Competitors are themselves responsible for the presentation or collection of the paper Time card & e-Time Card at the various controls and for the accuracy of the entries in the Time Card. The paper Time card & e-Time Card must remain on board the vehicle for the duration of the Leg and must be presented personally by a member of the crew at all the control points. At the end of each Leg the paper Time Card will be surrendered to the organisers. The e-Time Card will be retained by the competitor unless specifically asked for by the marshal at the Leg end till the end of the rally.

Officials are permitted to modify an entry which they have made but in such cases they must score out the original entry and replace it by a completely new one, which must be re-authenticated by a further signature. Any entry which appears to have been tampered with may be deemed not to have been made and may result in exclusion for the competitor.

A competitor losing his paper time card / e-Time Card will be excluded. If, accidentally, the wrong column is filled up in the paper Time Card it is the competitor's responsibility to ensure that the entries in the wrongly filled column are struck out and the correct column filled instead. The results will not be recomputed and consequential accrual of penalties will be solely the responsibility of the crews concerned.

SUPPLEMENTARY REGULATIONS

MARUTI SUZUKI RAID DE HIMALAYA X-TREME 2011

The time card & e-Time Card is the property of the organisers and upon retirement for any reason whatsoever MUST be returned to the organisers without delay.

- 11.2 Starting systems of Competitive Stages
 - 11.2.1 The Official Time throughout the entire Raid will be GPS Time expressed in accordance with the 24 hour clock. The GMT time differential offset will be +5.30 hrs. Hours, minutes and seconds will be shown thus e.g. 22:01:36
 - 11.2.2 The Start will be given with a Manual Count Down.
 - 11.2.4 The Competitive Stages will be timed to the second.
- 11.3 Early check in at the end of a Day
Crews can check in early without incurring any penalty at the end of all Legs.
- 11.4 No vehicle may be moved other than by its own power or by a competitor except:
 - a. **By outside means for the minimum distance necessary to extricate it from difficulty and place it back on the road.**
 - b. **By gravity.**
 - c. **By its own crew.**
 - d. **By another competing crew using their competition vehicle.**
- 11.5 Official time will be available with the Chief Timekeeper during the course of the Raid.
- 11.6 A compulsory drivers briefing will be held as per given schedule. All drivers and co-drivers have to attend this briefing. An attendance register will be maintained. Failure to attend this briefing will attract a penalty of Rs. 1000/- per crew member.
- 11.7 All competitors must check their vehicles into the start Parc Ferme at least 60 minutes before the flag off of the first car. The parc ferme shall be sealed 30 minutes before the flag off of the first car. Non-compliance may result in the vehicle not being allowed into the start parc ferme nor being allowed to start. The vehicles may be presented by a representative of the entrant. Competitors are required to line up for the start of a Leg at least 10 minutes before their Flag Off time.
- 11.8 The starting area shall also be regarded as a 'Parc Ferme'.
- 11.9 The exact time of start will appear on the Time Card.
- 11.10 Late arrivals will be subject to penalties in Art.10.2.4.
- 11.11 Since the crews have 10 minutes within which to report at the start of the event, of a leg or of a section, if they report within these 10 minutes the exact starting time shall be stamped on the Time Card. The 60 minutes referred to in Art 11.7 is for bringing the car to the parc ferme whereas the 10 minutes referred to in Art 11.10 is from the proposed restart time.
- 11.12 Crews are obliged to have their passage checked at all points mentioned on their Time Card and in the correct order.
- 11.13 The target times for covering the distances between any two consecutive time controls will not appear on the Time Card.
- 11.14 All the crews shall receive a road book containing a detailed description of the itinerary, which has to be followed. This itinerary is compulsory under pain of exclusion. Taking a shortcut is deviation from the itinerary and will invite exclusion.
- 11.15 A competitor who retires must immediately inform the Raid Headquarters / next Raid official and hand over his Time Card. He must also remove his Raid numbers or place a black "X" across them.
- 11.16 A competitor who has dropped out, or been excluded, on any Leg may not rejoin the Raid on the next Leg.

CONTROLS GENERAL PROVISIONS

- 12.1 All controls, i.e., passage and time controls, regrouping and neutralization zone controls, will be indicated by means of FMSCI approved standardized signals.
- 12.2 If a time control is wrongly located on the route, crews must check in as if it were correctly located.
- 12.3 If, through unavoidable circumstances, a time or passage control does not exist or is not operative, crews must continue along the official route.
For time controls, the time due at the next time control will be calculated by adding the times allowed for the sections concerned and will therefore remain unchanged.
- 12.4 The control areas will be marked as per details in Appendix "IV".
- 12.5 All control areas (i.e., all the areas between the first warning signal and the final one) are considered as 'Parc Ferme'.
- 12.6 The stopping time within any control area must not exceed the time necessary for carrying out control operations.
- 12.7 It is strictly forbidden under pain of exclusion:
- a) To enter a control area in any direction other than that of the Raid;
 - b) To re-cross or re enter a control area once checking in has taken place at this control.
- 12.8 The target check in time is the responsibility of the crews alone, who may consult the official GPS with the marshals. The post Marshals may not give them any information on this target check in time. Even if the post marshal offers his calculations and the competitor follows his advice and they turn out to be wrong it is the decision of the competitor to follow wrong advice that will be upheld.
- 12.9 Control posts shall be ready to function 1 hour before the target time for the passage of the 1st car. Unless the Clerk of the Course decides otherwise, they will cease to operate 15 minutes after the target time for the last crew Plus, MPL for that leg.
- 12.10 Crews are obliged to follow the instructions of the Marshall at any control post. Failure to observe this may lead to exclusion from the event at the discretion of the Stewards of the Meeting.
- 12.11 The Road Marshals and Post Chiefs shall be distinguished as indicated in Art.2.9.

Passage Control (PC) Time Control (TC)

A. Passage Controls

- 12.12 In order to check that the crews are respecting the itinerary in the road book, passage controls may be set up along the route.
- 12.13 The control zone will be defined using the following signs:
- a) Rubber Stamp on a Yellow sign (start of zone)
 - b) After approximately 50mtr, rubber stamp on red sign (passage control post)
 - c) Finally, approximately 50mtr further on, final beige sign with 3 transversal black stripes
- 12.14 The penalty for missing a PASSAGE CONTROL will be 60 penalty minutes for each PC missed.

B. Time Controls

- 12.15 At the end of transport stage time controls, the Marshals will write on the Time Card the check in time, which corresponds to the exact moment at which the

SUPPLEMENTARY REGULATIONS

MARUTI SUZUKI RAID DE HIMALAYA X-TREME 2011

- car crosses the Yellow Clock which marks the start of the Time Control (TC). The clocking of the Time Card will only be carried out if all the crew members are in the car. The procedure for the “end of a competitive stage” or ‘Flying Finish” Time Control is different and is outlined in Art 12.36.
- 12.16 The check in procedure commences the moment the car passes the Yellow Clock for the time control zone. The crew is forbidden to stop or to drive abnormally slowly between the zone entry sign and the control post.
- 12.17 The target check in time is that obtained by adding the time allowed for completing the road section to the starting time for that section. These times are expressed in hours, minutes and seconds are always shown from 00:01:00 to 24:00:00.
- 12.18 For road sections, the crew does not incur any penalty for early arrival if the car enters the control zone during the target check in minute.
- 12.19 For road sections any difference between the target check in time and the actual check in time will be penalized as follows
- The penalty for late arrival will be 1 minute per 1 min late, with 1 min. per min. late counting towards maximum permissible lateness.
 - The penalty for early arrival will be 2-penalty / min. per min. early, not counting towards maximum permissible lateness.
- 12.20 **At the time controls at the end of legs, crews are authorized to check in ahead of time without incurring a penalty except in those cases to the contrary informed by a written bulletin.**
- 12.21 For Special stages, the finish times will be taken to the second. All lapsed time from the start of the Special stage will count as a penalty.
- 12.22 Any failure on the part of the crew to observe the rules of the check in procedure defined above will be recorded by the Post Chief at that post and sent in a written report to the Clerk of the Course.
- 12.23 **The exclusion time (MPL) defined in the Supplementary regulations may be modified at any time by the Panel of the Stewards of the meeting, upon the proposal of the Clerk of the Course. The crews concerned shall be informed of this decision as soon as possible. Exclusion from the Raid for exceeding the maximum permitted lateness may only be announced at the end of a leg except in a case where a time condition is previously specified. On stages that are being run both ways MPL can be applied on a stage even. The competitors will be made aware of the time and place restrictions in writing before the start of a Leg. This instance will only occur if a military convoy / Raid return timing clashes with a competitor running late and into oncoming rally traffic.**
- 12.24 Where the section is a road section after a competitive section, the check in time entered on the Time Card shall constitute both the arrival time at the end of the competitive section and the starting time of the following transport section.
- 12.25 When a time control is followed by the start point of a competitive section, these two posts shall be included in a single control area, the signs of which shall be laid out as follows:
- Yellow sign with clock (Beginning of zone)
 - Red sign with clock (time control post) at a distance of approximately 50mtr.
 - Red sign with flag (start of the competitive section) at a distance of 20 to 50mtr.
 - 3 transversal black stripes in a circle on a beige background (end of control sign) approximately 50mtr further on.
- 12.26 At the time control at the finish of a road section the post chief will enter on the time sheet on the one hand the check in time of the crew. He will also swipe

the e-Time card. The Start marshal at the Red Clock on the other will enter the starting time for the for the competitive section. He will also swipe the e-Time Card.

There must be a 2 min. gap at least between the two to allow the crew to prepare for the start. **Furthermore, in the case of a puncture, the crew concerned will be allocated a maximum of 10 minutes extra. Punctures may be changed only by the crew with the equipment on board. Any time taken over this will be penalized at 1minute penalty per minute extra taken.**

- 12.27 Vehicles checking in to a control at the same minute shall leave that control in the order in which they arrived. A change in order may be authorised by the Post Marshal however.
- 12.28 The Time Card will not be returned to the crew unless both crew members are seated in their car, have their seat belts fastened and helmets strapped on.
- 12.29 If two or more vehicles arrive into the control point within the same minute, they will be restarted in their order of arrival at 2-minute intervals. The time between their check in and restart will be treated as Dead Time for each vehicle respectively.
- 12.30 The maximum permitted lateness (MPL) for each section or group of sections will be announced in an official bulletin prior to the start of the event. In no case can early arrivals be used as a means of reducing the lateness resulting in exclusion. Neither shall penalties for early arrival be taken into consideration when calculating the maximum lateness resulting in exclusion.

Competitive Sections

Competitive Sections are speed tests.

- 12.31 During the Competitive Sections, all members of the crew must wear approved crash helmets and have their seat belts appropriately adjusted and fastened, under pain of exclusion.
- 12.32 Crews are forbidden to drive in the opposite direction to that of the Competitive Section under pain of penalties which may go as far as exclusion.
- 12.33 At the starts of Competitive Sections, when the car with its crew on board has stopped in front of the starting control, the Marshall will enter the actual time of the start of the car in question on the Time Card (hour and minute), and will then countdown a loud: 30" 20" 10" and the last 5 seconds one by one. When the last 5 seconds have elapsed, the starting signal shall be given upon which the car must start immediately. The penalty for not starting within 60 seconds is exclusion.
- 12.34 The start of a Competitive Section may only be delayed in relation to the scheduled starting time by the Marshall in case of "force majeure".
- 12.35 A false start shall be penalized by 1 minute. This penalty does not exclude heavier penalties being inflicted by the Stewards of the Meeting, especially if the offence is repeated.
- 12.36 Competitive Sections will end with the signs being positioned as follows:
- a) Yellow Sign with a Yellow Clock Flag (beginning of zone)
 - b) After approximately 50mtr, Red sign with a Chequered Flag (Flying Finish). The time will be recorded when the centre of the front wheels of the car passes over an imaginary line drawn across the road at this point.
 - c) After another 50 to 100 m, "STOP" on a Red sign, where the crew stops and hands over the Time Card which is endorsed with the time that was recorded at the Flying Finish (hours, minutes and seconds). This time will also be

SUPPLEMENTARY REGULATIONS

MARUTI SUZUKI RAID DE HIMALAYA X-TREME 2011

the starting time of the following road section. (hrs. and min. only will be considered for this)

- d) Finally, 50mtr further on, final beige sign with 3 transversal black stripes.

Stopping or overtaking another competitor between the yellow warning sign and the stop sign is forbidden under pain of exclusion. Timing will be done on the flying finish line by hand timing and whistle.

12.37 **During a Competitive Section, any assistance is forbidden other than that of another racing crew using parts transported by a racing crew.**

12.38 The starting intervals of the Competitive Sections will respect the same dispositions as those laid down for starting legs.

12.39 Any crew refusing to start in a Competitive Section at the time and in the position allocated to it shall be given a penalty which may go as far as exclusion.

12.40 **Interruption of a Competitive Section:** When a Competitive Section has to be definitely stopped for any reason whatsoever before the last crew has covered it, a classification for the section may however be established by allocating to each crew which has been unable to complete the section because of the interruption, the slowest time set before the interruption.

This classification may be drawn up even if only one crew has been able to cover the Competitive Section in normal competing conditions. Only the Stewards of the Meet may apply this disposition after reception of reasons for the interruption from the Clerk of the Course.

Should the Stewards consider the slowest time set as abnormal, they may choose as the **scratch time** the one among the four slowest which seems the most suitable.

However, no crew which is totally or partially responsible for stopping in a Competitive Section may benefit from the measure. It will be given the time which it eventually sets provided that this time is greater than the scratch time awarded to the other crews.

Regrouping Controls / Neutralization Zones

12.41 Regrouping controls may be set up along the route. Their entry and exit controls shall be subject to the general rules governing the control posts.

The purpose of these regroupings will be to reduce the interval between the first car and the last car which may occur as a result of late arrivals and/or retirements.

12.42 In the interest of safety, DCOC's may be stationed in sections that could become dangerous or impassable. Should such a situation arise, this will, if possible, be reported to the COC who will request the Stewards of the Meet to decide that an Emergency Halt with Dead Time (Neutralization Zone) be established while drivers wait for conditions to return to a reasonably safe level.

12.43 On their arrival at such controls, the crews will hand the Post Marshall their Time Card. They will receive instructions on their starting time. Such Zones will be considered as Parc Ferme. The starting order shall be that of the arrival. At the moment of the start, they may be given a new Time Card and Starting time.

Parc Ferme

12.44 The cars shall be subject to the 'Parc Ferme' rules:

- a) From the moment they enter a starting area or a regrouping zone, until they leave one of these.
- b) From the moment they enter a control area until they leave it.

- c) From the moment they reach the end of the event until the time for lodging protests has expired.
 - d) From the moment they enter established Parc fermes at the beginning and end of Legs.
- 12.45 Repairs or refuelling are forbidden in Parc Ferme, except the washing of windows, lights, Raid plates, competition number plates and advertisements. Offenders may be excluded.
Refuelling is permitted in Parc ferme only when authorised in writing and when it is permitted for every single vehicle of the meet at that time.
- 12.46 If the Scrutineer notes that a vehicle seems to be in a condition which is not compatible with normal road use, they must immediately inform the Clerk of the Course or his Deputy thereof who may request that the car be repaired, failing which, excluded from the event.
- 12.47 In this case, the minutes used to carry out the intervention will be considered as the same number of minutes of lateness recorded in a road section. They will therefore be taken into consideration for the calculation of the exclusion. If this time is exceeded, exclusion may be announced.
- 12.48 In order to prevent a crew from trying to make up lost time after the repair; the crew will possibly be given a new starting time.
- 12.49 By way of exception, and under the supervision of the competent Marshal, the crew may, while in Parc Ferme:
- a) Change punctured or damaged tyre/s using equipment carried on board;
 - b) Have a new windscreen fitted with the possibility of having outside help;
 - c) Refuel if specifically authorized by a bulletin before the start of leg.
- 12.50 As soon as they have parked their car in the Parc Ferme, other than a Time Control, the drivers will leave the Parc Ferme and no member of the Crew will be allowed to re enter it.
- 12.51 To leave a Parc Ferme for the start or restart from a regrouping halt the crew shall be allowed to enter the Parc Ferme 10 minutes before its starting time.
- 12.52 If a crew is unable to present its car with the engine running:
- a) At a time control, a penalty of 1 minute shall be imposed, upto 10 minutes.
 - b) At the start of competitive sections, a penalty of 30 minutes shall be imposed.
- 12.53 Vehicles may be push started in parc ferme with such assistance as is available or pushed out of parc ferme altogether.
- 12.54 Any infringement of Parc Ferme regulations may result in exclusion from the event at the discretion of the Stewards of the Meet.
- 12.55 The competitor has to place the vehicle in the established Parc Ferme at the end of each leg. The opening and closing timings of Parc Ferme would be made available by the Area Co-ordinator at the end of the previous leg. The cars shall be subject to the Parc Ferme rules once they have entered it.

Final Control

- 12.56 As soon as each crew arrives at the end of Leg 6, they shall drive their car to the Parc Ferme. A brief check shall be carried out there to verify:
- a) its conformity with the car submitted at the pre event scrutineering.
 - b) if there is cause to impose the penalties prescribed.
- 12.57 The list of cars and the times they are to be presented for a thorough scrutineering will be posted on the Official Notice Board at the Raid HQ, Srinagar, and may be put up at the Parc Ferme at 2000 hrs on 16th October, 2011.
These competitors will report to Parc Ferme at the appointed time where their cars will be dismantled for a complete scrutineering. Any competitor who refuses to

SUPPLEMENTARY REGULATIONS

MARUTI SUZUKI RAID DE HIMALAYA X-TREME 2011

- present his car to the Scrutineer at the appointed time will be excluded.
- 12.58 Cars may be removed from Parc Ferme at the end of the event after the protest period has elapsed, subject to the approval of the Stewards of the Meet.
- 12.59 The absence of even one of the identification marks, as per Article 9.9 shall result in exclusion from the event.
- 12.60 Any fraud discovered, and in particular the fact of presenting as intact identification marks which have been retouched, will result in the exclusion of the crew, as well as that of any entrant or crew who has helped or been involved in the carrying out of the infringement. This will not prejudice the fact that the Stewards may be asked to impose heavier sanctions.
- 12.61 Without it being compulsory, thorough scrutineering involving the dismantling of the vehicle for the crews in the first three places in the Overall Classification, for those classed first in each group and possibly for any other crew, may be carried out at the absolute discretion of the Stewards of the Meet ex officio or following a protest or upon the decision of the Clerk of the Course.
- 12.62 Should the above-mentioned dismantling be the result of a protest, a deposit will be payable by the claimant in advance to cover all the costs incurred by the operation. If the protest turns out to be founded, the deposit shall be reimbursed to claimant, and charged to the defaulting competitor.

SERVICE

- 13.1 All service cars providing service in the event must be registered with the Organisers. Service Car Stickers to be positively collected at the time of registration. For each Service Vehicle per competitor, the Organizer will provide, for a cost of Rs. 1000/-, 2 service stickers per service car, which must be affixed one each on front doors.

Service mechanics will pay a fee of Rs. 500/- per mechanic and receive their ID Cards at Scrutiny itself.

Service crew would be responsible for their lodging and boarding requirements while on the Raid. If wishing to attend the Rally End dinner the service crews will be required to buy dinner coupons at Rs 500/- per person.

- 13.2 **Should a competitor wish to register more than one service vehicle, the balance service vehicles will be issued service stickers on payment of a registration fee of Rs.1500/ per service vehicle.**
- 13.3 The registration number and the corresponding sticker number of the service vehicle will be noted along with the competition number of the competitor(s) using the service vehicle/s in a register which will be maintained by the Organisers.
- 13.4 **Any competitor found to be receiving service from a vehicle not registered & without service stickers will be excluded.**
- 13.5 Any competitor whose registered service car is found inside a competitive stage; behaves in a manner that endangers other competitors or road users; causes disturbance in the normal way of life of the locals and is complained against, will be fined up to Rs.30,000/ and/or the competitor excluded at the discretion of the Stewards of the Meet.
- 13.6 Restriction on the movement of service vehicles:
Repairs and Refuelling are freely permitted throughout the event, except in those

cases expressly forbidden by a provision in the present regulations. Where they exist, the areas where all assistance is forbidden will be designated by a bulletin issued prior to the start of the event. Any infraction will entail immediate exclusion from the event.

Further, **ALL COMPETITIVE STAGES OF THE ROUTE WILL BE DESIGNATED AS UNSUITABLE FOR SERVICE VEHICLES.** In these sections the passage of service vehicles is prohibited except in an emergency and with the written authorization of the Post Chief at the commencement of the section. Other road sections may be designated by means of bulletins prior to the start of the event. **FOR AN INFRINGEMENT, A PENALTY DESCRIBED IN 13.5 WILL BE APPLIED. ALL THE COMPETITION CARS BEING SERVICED BY THE ERRANT SERVICE CAR/S WILL STAND TO BE AFFECTED BY AN ADVERSE DECISION. For e.g If a service car is registered service for 3 Four wheelers and 4 Two wheelers and it is found in a competitive stage and the penalty decided by the Stewards is exclusion, then all the 3 Four wheelers and 4 Two wheelers stand excluded !!!**

- 13.7 In any case service vehicles must not impede the progress of the Raid in any way. No service vehicle must ever drive in a direction opposite to that of the Raid cars in competitive sections, or deliberately block the passage of competing cars, or official vehicles, or prevent them from overtaking. For an infringement, a penalty of up to and including exclusion may be imposed on the car(s) they are servicing, at the discretion of the Stewards.
- 13.8 At the end of a leg, the organizers will provide a secure parking area for the repair and service of Raid vehicles. This area will be accessible to crews, registered service vehicles and registered service mechanics only.
- On completion of service, the raid vehicles must be placed in Parc Ferme.

FUEL ON THE ROUTE

The organisers will **NOT** provide refuelling to those competitors that have dedicated service. This facility will be available only to those competitors that are not taking dedicated service cars with them.

Fuel will be booked at Motoworld and delivered to the competitor who has made the booking at the specified refuelling halts.

Himalayan Motorsport is not selling fuel. We are merely positioning it at the refuelling halts for the competitor. Towards this facility, the competitor will advance money for the fuel and the transportation which will be bought on his behalf. This will be done at the scrutiny venue during scrutiny.

However, if the fuel is not collected at the specified refuelling halt it will be forfeited.

No refunds will be given to the competitor, in cash or kind.

No transfer of the fuel booked will be made to any other competitor even on the request of the competitor who originally booked the fuel.

INCASE THE ABOVE TERMS AND CONDITIONS ARE NOT ACCEPTABLE PLEASE DO NOT BOOK ANY FUEL. Booking of fuel implies that you have accepted the Terms and Conditions, regarding fuel, as above, without demur.

SUPPLEMENTARY REGULATIONS

MARUTI SUZUKI RAID DE HIMALAYA X-TREME 2011

PENALTIES

**14 THE START SHALL NOT BE AUTHORISED IF:
REASONS**

Entry fees not paid as per Entry Fee Table with reference to Art. 5.2 & Art. 5.13
No Personal Accident Insurance.
Not carrying compulsory Advertising as specified in chapter 7
Noise level in excess of 103 db @ 3000 rpm.

14.1 EXCLUSION

Servicing in Competitive Stage with outside help.	Traffic Laws 3rd infringement.
Unauthorized crew	Blocking of road/unsporting behaviour
No Identity Card	Non - Technical Conformity
Lateness exceeding time limit.	Not using Helmets and Safety belts in Competitive Stage
Absence of Identification marks	Speeding and testing vehicles in Secure Service Area.
Loss of paper Time Card or e-Time Card	Stopping between flying finish and stop point.
Driving in opposite direction of Competitive Stage.	Not wearing safety belts at all times while in car : 2nd offence
Deviating from the itinerary	—

14.1.1 EXCLUSION

For late arrival at Start of Leg by more than 10 minutes
Re-entry or wrong direction through control zone
Failure to start competitive sections within 60 seconds

14.2 PENALTIES IN TERMS OF TIME

1. For each minute of lateness at start of event/ leg/ control	1min
2. Violation of traffic laws 2nd infringement	15min
3. Early arrival per minute early	2 min
4. Late arrival at competitive controls per minute late	1 min.
5. False start at competitive sections	1min
6. Repairs in Parc Ferme per minute	1min

7. Car/ Truck presented at start /restarts of selective stages without engine running	30min
8. Missing a passage control	60min

14.3 **PENALTIES IN TERMS OF MONEY (INR)**

Late for Scrutiny	500.00
Absence/malfunctioning of mechanical / electrical parts required by national traffic regulations	500.00
Non functioning brake light	1000.00
Missing mud flap at scrutiny	500.00
Change of Navigator/ Driver	5000.00
Non submission of all paperwork/ documentation by time specified in 5.2(in addition to change of Entry Type fee payable)	1000.00
Absent/Covered license plate	1000.00
Absence of one competition number plate	250.00
Not wearing seat belt at all times while in car.	5,000/- per violation for transport stages, once. Exclusion for competitive stages
Absence of name of Driver/Co driver + blood Group on Vehicle front fenders	2500.00 for each time it is noticed
Violation of traffic laws 1st infringement	1000.00 + Police action as per codes
Servicing by unauthorized vehicle at any time or stage	30,000.00

14.4 **PENALTIES LEFT TO THE DISCRETION OF THE STEWARDS**

Unsecured equipment in passenger compartment	Fraudulent/unsporting action
Absence of any two competition numbers	Missing control entries in Time Card
Failure to stop at accident	Failure to report accident
Movement of service vehicles in restricted areas	Repairs in Parc Ferme
Service vehicles blocking passage of competing cars	Infringement of Parc Ferme Regulations
Failure to follow instructions of Chief Control Officer	Failure to produce scrutineering card on official request
Repeated false starts	Reporting late for scrutineering

SUPPLEMENTARY REGULATIONS

MARUTI SUZUKI RAID DE HIMALAYA X-TREME 2011

Failure to produce homologation forms and appendices at scrutineering	Failure to commence dismantling at finish within 30min by Chief Scrutineer of notification
---	--

REQUESTS, PROTESTS & APPEALS

- 15.0 A pre paid “Request Form” is attached for every leg of the Road book. Once filled, these can be deposited with the Area Coordinator at the end of Leg detailing the competitor’s grievance. **No request will be entertained that is not on the Request Form.** If the Request is lengthy and does not fit into the space on the form, a plain paper carrying the entire painful details may be appended to the form. Frivolous requests will not be entertained. Repeated requests of such nature will be reported to the Stewards who will fine at their discretion. **The carrying of the request will be decided by the C.O.C of the event. If the decision of the C.O.C is not palatable to the competitor he has the right to protest as given below.**
- 15.1 All protests shall be lodged in accordance with the stipulations of the National Sporting Code of FMSCI.
- 15.2 These have to be made within 30 minutes of the Final Provisional Results being put up on the final notice board at the end venue.
- 15.3 All protests must be lodged in writing and handed to the Clerk of the Course together with the sum of Rs. 15,000/- for each protest, which shall not be returned if the protest is judged unfounded.
- 15.4 No action will be taken unless this above formality is followed to the letter.
- 15.5 If the protest requires the dismantling of different parts of a car, the claimant must pay an additional deposit of Rs 6000/-.
- 15.6 The expenses incurred by the work and by transport of the vehicle shall be borne by the claimant if the protest is unfounded, or by the competitor against whom the protest is lodged if the claim is founded.
- 15.7 If the claim is unfounded, and if the expenses incurred by the protest (scrutineering, transport, etc.) are higher than the deposit amount, the difference shall be borne by the claimant. Conversely, if the expenses are less, the difference shall be returned to him.
- 15.8 The entrants may lodge an appeal against the decisions, in conformity with the stipulations of Chapter XIII of the National Sporting Code.
The appeal fee / bond is Rs. 80,000/ for 4 wheelers with Rs 40,000/- to be paid along with intention to appeal and balance Rs 40,000/- with grounds of appeal within 48 hours.

CLASSIFICATION

- 16.1 Penalties shall be expressed in hours, minutes and seconds.
- 16.2 The final results shall be determined by adding the penalties incurred in the special stages to the penalties incurred in the road sections plus any other penalties expressed in time as Supervisory Penalties. The finishing crew with the lowest total shall be proclaimed the overall winner, the next lowest second, and so on. The Group and Class results will be determined on the same basis.
- 16.3 In case of a tie, it will be resolved by determining the winner of most competitive stages.
- 16.4 The results shall be posted in accordance with the programme, unless the finish is unduly delayed in which case the results shall be posted as soon as possible after the arrival of the last car at the finish.
- 16.5 The classification is Provisional/official at the end of the Raid, and final 30 minutes after the posting of the results subject to Protests / Appeals, if any.
- 16.6 Provisional official classifications may be issued at the end of each leg. The times and places for posting these classifications will be in accordance with the program.
- 16.7 The qualifications necessary for the special prizes to be won are itemized and the decision of the Organizers will be final.
- 16.8 **In order to be classified in the results, entrants should have paid to the Organizers any fines, imposed under these Supplementary Regulations before provisional results are published.**
- 16.9 **Team entry**
 - a) Each team shall consist of a minimum of 3 vehicles and a maximum of 5.
 - b) For classification, at least 3 vehicles in each team must be finishers. The penalty points of the 3 best finishers of each team will be added. The team having the lowest penalty points will be adjudged the winner and will be eligible for awards.
 - c) Each competing crew can be part of only one Team.
 - d) There are no restrictions on the number of team entries that a trade organisation or a club may enter.

PRIZES – TROPHIES

17 Prizes Overall

1st	Trophy
2nd	Trophy
3rd	Trophy
4th	Trophy
5th	Trophy

Group Prizes for Cars

The first 3 winners from each Group formed as specified below will be awarded a Group winner trophy. Classes will not count towards a trophy.

Group T1: Modified Cross Country Cars (2wd & 4X4)

Irrespective of Class (cubic capacity).

Group T2: Series Cross Country Cars (2 WD & 4X4)

SUPPLEMENTARY REGULATIONS

MARUTI SUZUKI RAID DE HIMALAYA X-TREME 2011

Irrespective of Class (cubic capacity).

Trucks

Overall

1st	Trophy
2nd	Trophy
3rd	Trophy

TEAM PRIZE

CARS

1st Prize	Trophy
------------------	---------------

TRUCKS

1st Prize	Trophy
------------------	---------------

Prize for the winning Team is only applicable with the entry of a minimum of hree Teams and provided that at least 3 finishers are there per category i.e. Cars / Trucks, but these may be in any Class entered.

COUP de DAMES

CARS & TRUCKS

1st Prize	Trophy
------------------	---------------

This is a prize for the Winner amongst an “All Ladies Team” in the Four Wheeler Category.

TUNERS TROPHY

There will be a prize for the tuner of the 1st Overall Car.

- 17.1 The Organizers may at their discretion:
 - a) offer awards in addition to those specified in these Supplementary Regulations;
 - b) distribute the awards, if through unforeseen or special circumstances, the competition is stopped before its scheduled completion.
- 17.2 **It is mandatory to wear the Official Event Jacket for the Compulsory Driver’s briefing, the Press Conference and the Prize Distribution ceremony of the 13th Maruti Suzuki Raid de Himalaya 2011. Those not wearing this jacket, which will be provided to all competitors, will be refused permission to enter the venue. This jacket will form the outer most garment worn by the person during the ceremony.**

APPENDIX I – DUTIES OF THE JUDGES OF FACT

Transport Section and Competitive Section:

The itinerary between two successive time controls.

Parc Ferme:

Zone in which no repairs or intervention is possible, except in cases expressly provided for by these Regulations.

Bulletin:

Official bulletin, which is an integral part of the regulations of the event and intended to modify, clarify or complete the latter. The bulletins will be numbered and dated. The entrants (or crew members) must confirm receipt thereof by signature. The bulletins are established by the Organizers, up until the day of scrutineering. During the event they will be submitted for the approval of the Stewards and issued after receipt of the relevant approval, except with regard to possible modifications to the itinerary.

Time Card:

Card intended for the stamps and/or signature of the different control points scheduled on the itinerary.

A card must be issued for each leg.

E-Time Card

A plastic card with a chip locked on to it for the purpose of receiving times during the rally, which are stored electronically. The e-Time Card is swiped against the timer clock at every Time Control.

Section:

All the zones:

- between the start and the first regrouping halt
- between two successive regrouping halts
- between the last regrouping halt and the finish of the event.

Leg:

Each part of the event, separated by a stopping time of minimum 9 hours, or by a stopping time at least equal to the duration of the course completed if this is less than 7 hours.

Neutralization:

Time during which the crews are stopped by the Raid organizers for whatever reason.

Regrouping:

Stop scheduled by the organizers to enable the theoretical times to be observed on the one hand, and on the other, to regroup the cars still in the event. The stopping time may vary according to the crews.

APPENDIX II – COMPETITORS’ RELATIONS OFFICER

Principal Missions:

Inform the competitors and play the role of a stabilizing factor at all times. He will attend the meeting of the Panel of the Stewards of the Meet, in order to keep abreast of all the decisions taken.

The Competitors’ Relations Officer must be able to be easily identified by the competitors. To this end :

1. He will wear a green poncho.
2. Be introduced to the competitors when there is a drivers’ briefing.
3. His photograph will be included in a Bulletin if possible.

Presence At The Running Of An Event:

When the Secretariat is opened, he will have the Secretary of the Meeting draft a schedule of his duties which shall be posted on the notice board of the event and which shall include:

Presence :

At the Secretariat.

At the start of the scrutineering.

At the regrouping Parc Ferme at end of event halts and sections.

Near the “parc ferme” at the arrival (the latter being dependent on the Raid timetable)

Function:

Give accurate answers to all questions asked.

Provide all information or additional clarifications in connection with the regulations and the running of the event.

Avoid forwarding questions to the Panel of the Stewards of the Meet which could be solved satisfactorily by a clear explanation, with the exception of protests (for example, clarify disputes over times, with the assistance of the timekeepers).

The Competitors’ Relations Officer shall refrain from saying anything or taking any action which might give rise to protests.

APPENDIX III DUTIES OF THE JUDGES OF FACT

Judges of fact are required to perform the following duties:

1. To bring to the notice of the clerk of the course of any unfair practices or irregularities adopted by the competitors during the running of the event.
2. To bring to the notice of the clerk of the course the presence of any unauthorized service vehicle present within the competitive stages.
3. To bring to the notice of the clerk of the course any cases of competition vehicles taking shortcuts or straying off the defined itinerary as specified in the official Road book. They would also be required to report incidents of competitors infringing rules pertaining to parc ferme, both at the night halts as well as those of the time control areas.
4. Protest may not be made against the decision of the judge, which shall be acceptable as final unless corrected as hereinafter provided. The finding although final as regards the fact decided, shall not constitute a statement of results because it will not have taken into account the conditions under which the automobiles have completed the course.
5. A mistake by a judge may be corrected by him with the approval of the Stewards of the meeting.

SUPPLEMENTARY REGULATIONS

MARUTI SUZUKI RAID DE HIMALAYA X-TREME 2011

APPENDIX IV – CONTROL SIGNS

DIRECTION	CONTROL TYPE	CONTROL ZONE			DIRECTION
		YELLOW SIGNS	RED SIGNS	BEIGE SIGNS	
↕					↕
↔	PASSAGE CONTROL		← 25mts →	← 25mts →	↔
↔	LEG START/FINISH TIME CONTROL		← 25mts →	← 25mts →	↔
↕	END TIME CONTROL (Transport) & CS START	25mts ← →	25mts ← →	25mts ← →	↕
↔	END OF CS	100mts ← →	100mts ← → 300mts	25mts ← →	↔

APPENDIX V – ADVERTISING

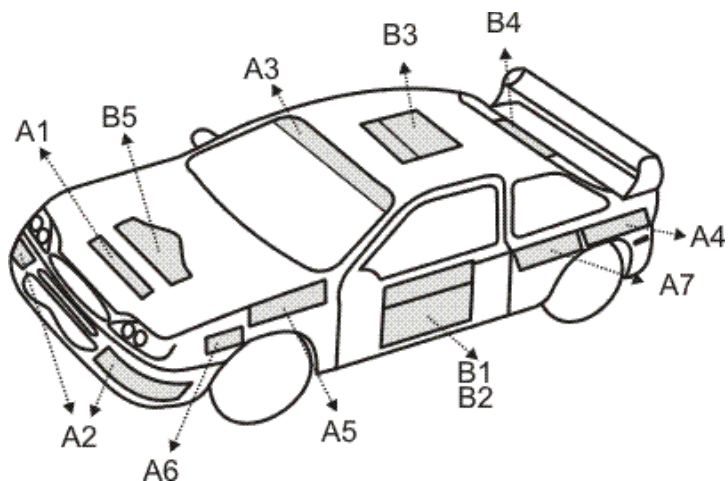

- A1 HIMALAYAN MOTORSPORT STICKER
- A2 Sponsor 2
- A3 Title Sponsor of the Event
- A4 Hospitality Sponsor of the Event
- A5 Name and Blood Group of the Crew
- A6 Sponsor 3
- A7 Himalayan Motorsport
- B1-5 Numbered Competition Stickers Adventure Trial 2011

In the event that a competitor wishes to apply advertising that conflicts with the above reserved layout he/she may opt for a “Sponsored Entry” . In this case the competitor is only obliged to affix the stickers defined as A1, A3, A5, and B1 to B5. The rear windshield will be retained for the Himalayan Motorsport sticker. The other areas are free for the sponsored competitors use.

SUPPLEMENTARY REGULATIONS
MARUTI SUZUKI RAID DE HIMALAYA X-TREME 2011
APPENDIX VI – SCRUTINY LIST

Sr. No.	Particulars	Description
1	Competition #	Displayed as per Appendix V
2	Registration #	Make a sticker 8in X 6in with a "White" background & "Black" letters and numbers. Location is on the front of the bonnet above the grill. Letters & Numbers to be sized to 2 inches and having a thickness of 3 mm. to be made from reflective stickers.
3	Name & Blood Group	For the Driver & Co-Driver to be displayed on black background of 4in. X 8in. dimension. with white letters & symbols. Location is on top-end of the both front fenders. Letters & symbols sized to 1 inch and thickness - 3mm, to be made from reflective sticker
4	Compulsory ads	Displayed as per Appendix V
5	Head Lights – Main & Dipper	Functional in High Beam/ dipper mode; bulbs should be of twin filament type
6	Additional Lights	Should not be mounted above the lower level of the front windscreen and must be in pairs.
7	Parking Lights	Fully Functional
8	Side Indicators	Fully Functional
9	Tail Lights	Fully Functional
10	Reverse Lights	Fully Functional
11	Number Plate Lights	Fully Functional
12	Brake Lights	Fully Functional
13	Bonnet & Boot fasteners	To be of American bayonet type
14	Towing eye Front/ Rear	Towing eye should be painted red. If of the removable screw-on type, should be carried for inspection during scrutiny.
15	Windshield Wipers	Rubber must not be cracked, windshield washer must work
16	Horn	Should be heard loud & clear in the next district!
17	Tyre Condition (4mm min.)	Should be in good condition having a minimum tread depth of 4mm atleast, sidewalls should not be damaged
18	Mud Flaps - Front/ Rear	Must on all 4 wheels. May be the OE unit supplied
19	Wheel Rim Size	—

20	Circuit Breaker	Compulsory
21	Safety Harness (4 Pt.)	—
22	Head Restraint	Must for both crew members
23	Roll Cage	45 mm as per FMSCI revised specs for 2011
24	Fire Extinguisher	—
25	Rear view Mirrors	1 each on the driver and co-driver side mounted on the doors and one inside the cabin for the driver
26	Red Triangles	2 in number, Made of reflective material, must be secured firmly
27	First-Aid Kit	Medicines must be checked for Expiry Date
28	Survival Rations	For both crew members, individual portions for at least 24 hours. Must consist of potable water, high energy food, etc.
29	Brakes – Foot & Parking	Parking - Should lock between 5-8 notches
30	Ballast	—
31	Fuel Tank Position	Must be a unit manufactured by an OE supplier.
32	Exhaust Group A/ Group N	—
33	Helmet Driver & Co-driver	Mandatory for both crew members. Must be at least ISI marked. Open face recommended
34	Identity Card	Issued by Himalayan Motorsport Association, to be secured and displayed on the rear left window.
35	Identification Marks	Put on engine and body shell using wires, special numbered seals and/ or paint
36	Sleeping Bag	Must for all competitors, suitable for a temperature range of -5C to +25C.
37	Snow Chains (Min. 2 pcs.)	Minimum for 2 tyres, must be secured to the tyre by a sturdy nylon rope.
38	Exhaust noise	98/103 db @ rpm max limit
39	Tarpaulin	For spreading under the car during service, repair, breakdown. (4m x 3 m plastic).